

Generalisations of the Tits representation

Daan Krammer

September 29, 2008

Mathematics Subject Classification:

primary 52C35, secondary 20F55, 22E40

Abstract

We construct a group K_n with properties similar to infinite Coxeter groups. In particular, it has a geometric representation featuring hyperplanes, simplicial chambers and a Tits cone. The generators of K_n are given by 2-element subsets of $\{0, \dots, n\}$. We provide some generalities to deal with groups like these. We give some easy combinatorial results on the finite residues of K_n , which are equivalent to certain simplicial real central hyperplane arrangements.

1 Introduction

A *Coxeter group* is a group W presented with generating set S and relations s^2 for all $s \in S$ and at most one relation $(st)^{m(s,t)}$ for every pair $\{s, t\} \subset S$ (where $m(s, t) = m(t, s) \geq 2$ if $s \neq t$). It is known that then the natural map $S \rightarrow W$ is injective; we think of it as an inclusion. We call the pair (W, S) a *Coxeter system* and $\#S$ its rank.

We generalise this as follows. For any set S , let F_S denote the free monoid on S . A *fully coloured graph* is a triple (V, S, m) where V, S are sets, $m: V \times S \times S \rightarrow \mathbb{Z}_{\geq 1} \cup \{\infty\}$ is a map, and an *action* $V \times F_S \rightarrow V$ written $(v, g) \mapsto vg$ is specified, satisfying the following.

- The action of F_S on V is transitive. (1)
- For all $v \in V$, $s \in S$ we have $(vs)s = v$.
- Let $v \in V$, $s, t \in S$. Then $m(v; s, t) = 1$ if and only if $s = t$. Moreover $m(v; s, t) = m(v; t, s)$ and $m(v; s, t) = m(vs; s, t)$. Also, if $k := m(v; s, t)$ is finite then $v(st)^k = v$.
- The set V is *simply 2-connected*. That is, let (V', S, m') satisfy the above too and let $f: V' \rightarrow V$ be a map satisfying (i) $(fv)s = f(vs)$ for all v, s ; (ii) $m'(v; s, t) = m(fv; s, t)$ for all v, s, t . Then f is injective. (2)

As the name suggests, a graph is involved: it has vertex set V and edges $\{x, xs\}$ of colour s whenever $x \in V$, $s \in S$. In this language, (1) means that the graph is connected.

Every Coxeter system (W, S) gives rise to a *Coxeter fully coloured graph* (W, S, m) where one defines $m(w; s, t)$ to be the order of st and the action $W \times S \rightarrow W$ to be multiplication.

More generally, every simplicial real hyperplane arrangement gives rise to a fully coloured graph; see lemma 8.

Equivalent to (2) is saying that if we attach 2-cells to the graph along loops with label $(st)^{m(v;s,t)}$ based at v , then the result is simply connected.

Let (V, S, m) be a fully coloured graph. For $I \subset S$, an I -residue is a subset of V of the form $\{vg \mid g \in F_I\}$. We also call it an r -residue if $r = \#I$.

A celebrated result by Tits [B, section 5.4.4], [V], [H, section 5.13] implies that every Coxeter group W has a faithful linear representation $W \rightarrow \text{GL}(Q)$ whose dimension equals the rank of W . His result gives more than this though. In particular, there is a W -invariant convex cone $U \subset Q$, known as the Tits cone, and W acts properly on the interior of U . This is a marvellous example of a local-to-global result: the assumptions of the theorem are local, the assertion global.

Our first result, theorem 24 (together with its corollaries in the same section) is a generalisation of Tits's result to fully coloured graphs. Our proof is not very different from Tits's original one in [B, section 5.4.4]. As a fully coloured graph doesn't involve a group, the theorem doesn't mention any linear representation. Instead, it gives a convex cone U in a real vector space Q of dimension $\#S$, a collection \mathcal{A} of hyperplanes in Q , and a natural bijection between V and the set of connected components of $U \setminus (\cup \mathcal{A})$. Again, the assumptions are local (we call them a *realisation*; see definition 12) and the assertion is global.

Before theorem 24 can be applied to a particular case, two hurdles need to be taken which are trivial in the case of Coxeter groups: (a) the combinatorial challenge of finding a fully coloured graph; and (b) the algebraic hurdle of finding a realisation. Contrary to the Coxeter case, a fully coloured graph may not have a realisation, and it is unclear how many it has in general.

We approach (b) as follows. We define a $(2, 3, \infty)$ -graph to be a fully coloured graph (V, S, m) such that $m(v; s, t) \in \{2, 3, \infty\}$ for all v, s, t and which has a (necessarily unique) realisation of a specific form; see definition 30 for the details. The fully coloured graph associated with a Coxeter system (W, S) is a $(2, 3, \infty)$ -graph if and only if $m(s, t) \in \{2, 3, \infty\}$ for all $s, t \in S$.

Our second main result, theorem 35, gives a combinatorial local condition for a fully coloured graph to be a $(2, 3, \infty)$ -graph. In particular, a fully coloured graph is a $(2, 3, \infty)$ -graph if and only if its k -residues are for all $k \leq 3$.

By a $(2, 3)$ -graph we mean a $(2, 3, \infty)$ -graph (V, S, m) such that $m(v; s, t) \in \{2, 3\}$ for all v, s, t . Up to isomorphism, there is just one non-Coxeter $(2, 3)$ -graph of rank 3. It plays a special role in the paper and is depicted in figure 2.

For $n \geq 0$, let K_n be the group presented by a set $T_n \subset K_n$ of $\binom{n+1}{2}$ generators written

$$T_n = \left\{ \binom{a}{b} \mid a, b \in \{0, 1, \dots, n\}, a < b \right\}$$

and relations s^2 for all $s \in T_n$ and

$$\binom{a}{b} \binom{c}{d} \binom{a}{b} \binom{c}{d}$$

whenever $0 \leq a < b \leq c < d \leq n$;

$$\binom{a}{b} \binom{a+x}{b-y} \binom{a}{b} \binom{a+y}{b-x}$$

whenever $x, y \geq 0$ and $0 \leq a < a+x+y < b \leq n$; and

$$\binom{a}{b-z} \binom{a+y}{b} \binom{a}{b-x} \binom{a+z}{b} \binom{a}{b-y} \binom{a+x}{b}$$

whenever $x, y, z > 0$ and $0 \leq a \leq a+x+y+z = b \leq n$.

Some motivation for this definition is provided by the observation that there exists a K_n -action on $\{1, \dots, n\}$ given by

$$\binom{a}{b}(x) = \begin{cases} a+b+1-x & \text{if } a+1 \leq x \leq b, \\ x & \text{otherwise.} \end{cases}$$

Based on the presentation of K_n , we define a class of fully coloured graphs called *admissible graphs* in definition 59. One of them, written Γ_n , has the property that the underlying graph is the Cayley graph of (K_n, T_n) . More precisely, K_n acts from the left on Γ_n ; the action on the vertex set of Γ_n is simply transitive; and there exists a vertex 1_u of Γ_n such that, for all $a \in K_n$, the pair $\{1_u, a 1_u\}$ is an edge if and only if $a \in T_n$.

The colour of the edge $\{x 1_u, x a 1_u\}$ ($x \in K_n, a \in T_n$) does *not* depend only on a . Equivalently, the action of K_n on the colour set of Γ_n is non-trivial. For otherwise K_n would have to be a Coxeter group; see lemma 10 and the text after lemma 49.

Our third main result, theorem 67, states that every admissible graph (in particular, Γ_n) is a $(2, 3)$ -graph. We give a case-by-case proof of the theorem by looking at every 3-residue separately.

It follows that K_n is linear; see corollary 69. The fact that some admissible graphs have a group (namely, K_n) for vertex set, is ignored in most of the paper.

Contrary to the Coxeter case, a residue of Γ_n is not necessarily isomorphic to any Γ_k . It can be shown that, up to isomorphism, admissible graphs are the same thing as residues of Γ_n (use corollary 29). We don't take this as a definition for admissible graphs for technical reasons.

Among the $(2, 3)$ -graphs the finite ones are especially interesting. Theorem 24 associates a simplicial real central hyperplane arrangement to each of them. We list the irreducible rank 4 $(2, 3)$ -graphs without proof in proposition 79. There are four of them, two of which are Coxeter and two of them are not. Both of the non-Coxeter ones are admissible. This suggests that Γ_n may be a good source for finite $(2, 3)$ -graphs.

In section 2, titled *Fully coloured graphs and their realisations*, we introduce fully coloured graphs and generalise the Tits representations of Coxeter groups to them.

In section 3 with title $(2, 3, \infty)$ -Graphs we define $(2, 3, \infty)$ -graphs and classify them locally.

Section 4, titled *An example*, studies admissible graphs and their relation with $(2, 3)$ -graphs.

Acknowledgement Many thanks to both referees for many useful comments.

2 Fully coloured graphs and their realisations

For a set S , let F_S be the free monoid on S . We consider S to be a subset of F_S . If $S \subset T$ then $F_S \subset F_T$.

Definition 3. A *fully coloured graph* is a triple (V, S, m) where V, S are sets, $m: V \times S \times S \rightarrow \mathbb{Z}_{\geq 1} \cup \{\infty\}$ is a map, and an *action* $V \times F_S \rightarrow V$ written $(v, g) \mapsto vg$ is specified (though suppressed in the notation) satisfying the following.

◦ The action of F_S on V is transitive. (4)

◦ For all $v \in V$, $s \in S$ we have $(vs)s = v$. (5)

◦ Let $v \in V$, $s, t \in S$. Then $m(v; s, t) = 1$ if and only if $s = t$. (6)
Moreover $m(v; s, t) = m(v; t, s)$ and $m(v; s, t) = m(vs; s, t)$. Also, if $k := m(v; s, t)$ is finite then $v(st)^k = v$.

◦ The set V is *simply 2-connected*. That is, let (V', S, m') satisfy the above too and let $f: V' \rightarrow V$ be a map satisfying (i) $(fv)s = f(vs)$ for all v, s ; (ii) $m'(v; s, t) = m(fv; s, t)$ for all v, s, t . Then f is injective. (7)

Apart from the m -function, (4)–(6) define what is known as a thin chamber system [T], [R], but we shall not use this term.

In an earlier version of the paper we also considered *coloured graphs*. We keep the term *fully coloured graph* for backward compatibility only.

Let (V, S, m) be a fully coloured graph and let $I \subset S$. An I -*residue* is a subset of V of the form vF_I where $v \in V$. We also call it an r -*residue* if $r = \#I$.

Let R be the $\{s, t\}$ -residue through v . It follows from (6) that $m(v; s, t)$ depends only on (R, s, t) . We write it as $m(R; s, t)$ accordingly.

The following well-known result motivates the definition of fully coloured graphs.

Lemma 8. *Let Q be a finite dimensional real vector space. Let \mathcal{A} be a simplicial central hyperplane arrangement in Q (see [OT] for these notions). Then there exists a fully coloured graph (V, S, m) such that V is the set of closed chambers of \mathcal{A} and, for every k -residue R with $k \leq 2$, the codimension in Q of $\bigcap_{C \in R} C$ is k .*

Proof. In this proof, we consider closed chambers of \mathcal{A} only. By a *panel* we mean a 1-codimensional intersection of chambers. Let E be the set of panels. For a chamber C , let $E(C)$ be the set of panels contained in C . Then $\#E(C) = d$ where $d = \dim Q$. Let S be any set of d elements. We shall construct a colouring map $g: E \rightarrow S$ whose restriction $E(C) \rightarrow S$ is bijective for every $C \in V$.

Let C_1, C_2 be adjacent chambers, that is, their intersection e has codimension 1. Two bijections $f_i: E(C_i) \rightarrow S$ are called *compatible* if $f_1(e) = f_2(e)$ and $\text{cod } f_1^{-1}(s) \cap f_2^{-1}(s) = 2$ for all $s \in S \setminus \{f_1(e)\}$.

Observe now that every bijection $f_1: E(C_1) \rightarrow S$ is compatible with precisely one bijection $f_2: E(C_2) \rightarrow S$.

If one chooses $g_0 = g|_{E(C_0)}$ for one chamber C_0 to begin with, there is at most one way to extend g_0 to a map g with the required properties: to find the restriction $g_1 = g|_{E(C_1)}$ for another chamber C_1 one chooses a path from C_0 to C_1 and extends g_0 along the path by compatibility. It remains to show that g_1 does not depend on the path from C_0 to C_1 chosen. It is enough to prove this in the case where the intersection of all chambers involved (that is, in either path) has codimension 2. A moment's thought shows that it is true. It follows that the colouring map g exists as promised.

The proof is finished by taking the action $V \times S \rightarrow V$ to be $C_1 s := C_2$ whenever $e = C_1 \cap C_2$ is a panel and $c(e) = s$, and taking m to be minimal, that is, $m(C; s, t)$ is half the cardinality of the $\{s, t\}$ -residue through C . \square

Definition 9. An *automorphism* g of a fully coloured graph (V, S, m) consists of a permutation of V and one of S , both written g , such that $g(vs) = (gv)(gs)$ and $m(v; s, t) = m(gv; gs, gt)$ for all v, s, t .

As explained in the introduction, every Coxeter system gives rise to a fully coloured graph. The following converse is easy.

Lemma 10. *Let $\Gamma = (V, S, m)$ be a fully coloured graph. Let W be a group acting on Γ by automorphisms of the fully coloured graph which don't permute the colours (see definition 9). If W acts simply transitively on V then W is a Coxeter group.*

More precisely, let $v \in V$ be a vertex, and let T be the set of elements $t \in W$ such that $\{v, tv\}$ is an edge (that is, $tv = vs$ for some $s \in S$). Then (W, T) is a Coxeter system. \square

Remark 11. (a). Let (V, S, m) be a fully coloured graph. There is an equivalence relation on V with two equivalence classes such that v, vs are not equivalent for all $v \in V, s \in S$. In particular, $v \neq vs$. This follows from the simple 2-connectedness (7) and the fact that the relations (5), (6) have even length.

(b). In a Coxeter fully coloured graph we have $\#R = 2m(R; s, t)$ for every $\{s, t\}$ -residue R . In an arbitrary fully coloured graph it is still true that $\#R$ divides $2m(R; s, t)$, but equality doesn't necessarily hold, as the following example shows.

Put $V = (\mathbb{Z}/2)^3$ and $S = \{r, s, t\} \subset V$ where $r = (1, 0, 0)$, $s = (0, 1, 0)$, $t = (0, 0, 1)$. Let S act on V by right multiplication. Define $m(v; a, b) = 2$ for all v, a, b except if $\{a, b\} = \{s, t\}$ and $v \in R := \langle s, t \rangle$ in which case we put $m(v; s, t) = 4$. Then (V, S, m) is a fully coloured graph but $2m(R; s, t) = 8 \neq 4 = \#R$.

Let Q be a real vector space. A *hyperplane* in Q is a 1-codimensional linear subspace. An *open (respectively, closed) half-space* is a subset of Q of the form

$f^{-1}(\mathbb{R}_{>0})$ (respectively, $f^{-1}(\mathbb{R}_{\geq 0})$) where $f: Q \rightarrow \mathbb{R}$ is a nonzero linear map. If H is one of the above half-spaces, then the *boundary* ∂H is defined to be $f^{-1}(0)$.

Definition 12. Let $\Gamma = (V, S, m)$ be a fully coloured graph. A *realisation* of Γ consists of the data (13)–(14) satisfying properties (15)–(17) below.

- For every $v \in V$ a real vector space $P(v)$ with basis $\{p(v, s) \mid s \in S\}$ (a set in bijection with S) is specified. (13)
- Whenever $w = vs$ ($v, w \in V, s \in S$) an isomorphism (14)

$$\phi_{v,s}: P(v) \rightarrow P(w)$$

is specified such that $p(v, t) \phi_{v,s} = p(w, t)$ for all $t \in S \setminus s$.

- Let Q denote the quotient of the disjoint union $\sqcup_{v \in V} P(v)$ by the smallest equivalence relation \equiv such that $x \phi_{v,s} \equiv x$ for all v, s and all $x \in P(v)$. Then the natural map $P(v) \rightarrow Q$ is bijective for one hence all $v \in V$. (15)

Note that the condition (15) is equivalent to $\phi_{v_1, s_1} \cdots \phi_{v_n, s_n} = 1$ (indices in \mathbb{Z}/n) whenever $v_i s_i = v_{i+1}$ for all i . It is sufficient for this to hold for $\#\{s_1, \dots, s_n\} = 2$, by (7).

The image in Q of $p(v, s)$ is written $q(v, s)$. It follows from (15) that Q is a real vector space with basis $\{q(v, s) \mid s \in S\}$ (a set in bijection with S) whenever $v \in V$. For $v \in V$ we define the *chamber* $C(v) = \sum_{s \in S} \mathbb{R}_{\geq 0} q(v, s)$.

- We have $C(v)^0 \cap C(vs)^0 = \emptyset$ for all $v \in V, s \in S$, where 0 denotes the relative interior. (16)
- Let $R \subset V$ be an $\{s, t\}$ -residue, $s \neq t$, and write $X = \cap_{v \in R} C(v)$. (17)

If $k = m(R; s, t)$ is finite then there exist k (distinct) hyperplanes in Q containing X such that every component of the complement of these hyperplanes meets $C(v)$ for a unique $v \in R$. In particular, $\#R = 2m(R; s, t)$.

If $m(R; s, t)$ is infinite then $\cup_{v \in R} C(v)$ is contained in some closed half-space whose boundary contains X . □

Suppose $vs = w$ ($v, w \in V, s \in S$). Then there are unique $c_t \in \mathbb{R}$ ($t \in S$) such that

$$q(w, s) = \sum_{t \in S} c_t q(v, t).$$

Now (16) is equivalent to $c_s < 0$.

Example 18. It is well-known and not hard to show that every Coxeter fully coloured graph admits a (covariant) realisation

$$p(v, s) \phi_{v,s} = -p(vs, s) + \sum_{t \in S \setminus \{s\}} 2 \cos \frac{\pi}{m(s, t)} p(vs, t). \quad (19)$$

The dual form is more common; see [B, section 5.4.3], [H, section 5.3], [V].

Consider a fully coloured graph $\Gamma = (V, S, m)$ with a realisation with the above notation. Let g be an automorphism of Γ which we recall may permute the colours (definition 9). For $v \in V$, define the g -folding map $g_*: P(v) \rightarrow P(gv)$ by $g_*p(v, s) = p(gv, gs)$. We say that g preserves the realisation if, for all $v \in V$ and $s \in S$, we have a commuting diagram

$$\begin{array}{ccc}
 P(v) & \xrightarrow{\quad g_* \quad} & P(gv) \\
 \phi_{v,s} \downarrow & & \downarrow \phi_{gv,gs} \\
 P(vs) & \xrightarrow{\quad g_* \quad} & P((gv)(gs)).
 \end{array} \tag{20}$$

Lemma 21. *Let $\Gamma = (V, S, m)$ be a fully coloured graph with a realisation. Let G be the group of automorphisms of Γ preserving the realisation. Then, there exists a unique linear representation $L: G \rightarrow \text{GL}(Q)$, $g \mapsto L_g$ such that $L_g q(v, s) = q(gv, gs)$ for all g, v, s . In particular, $L_g C(v) = C(gv)$.*

In corollary 26 below we shall see that this representation is faithful.

Proof. Let $g \in G$. For all $v \in V$, define $L_{g,v} \in \text{GL}(Q)$ by the commuting diagram

$$\begin{array}{ccc}
 P(v) & \xrightarrow{\quad g_* \quad} & P(gv) \\
 \downarrow & & \downarrow \\
 Q & \xrightarrow{\quad L_{g,v} \quad} & Q
 \end{array} \tag{22}$$

where the top arrow is a g -folding map and the vertical arrows are natural. By the commuting diagram (20), $L_{g,v} = L_{g,vs}$. By an obvious induction, $L_{g,v}$ does not depend on v ; let L_g be their common value. By (22) we have $L_g q(v, s) = q(gv, gs)$. That $g \mapsto L_g$ is a homomorphism follows by $L_g L_h q(v, s) = L_g q(hv, hs) = q(ghv, ghs) = L_{gh} q(v, s)$. \square

Remark 23. Suppose that the fully coloured graph (V, S, m) admits a realisation. Let $v \in V$ and let $s, t \in S$ be distinct. Then the $\{s, t\}$ -residue through v has $2m(v; s, t)$ elements. This follows immediately from (17). In particular, $vs \neq vt$.

In the case of Coxeter groups, this is the usual proof that the order of st equals $m(s, t)$ rather than a proper divisor of it.

Let (V, S, m) be a fully coloured graph. For $v, w \in V$, define $d(v, w)$ to be the least $k \geq 0$ such that there are $s_1, \dots, s_k \in S$ with $vs_1 \cdots s_k = w$. Then d is a metric. By a *semi-geodesic* we mean a tuple (v_1, \dots, v_n) of vertices such that $d(v_1, v_n) = \sum_{i=1}^{n-1} d(v_i, v_{i+1})$.

For $v \in V$, $s \in S$, we define

$$H(v, s) := \left\{ \sum_{t \in S} c_t q(v, t) \mid c_t \in \mathbb{R} \text{ for all } t \in S \text{ and } c_s \geq 0 \right\} \subset Q.$$

Equivalently, $H(v, s)$ is the closed half-space in Q containing $C(v)$ whose boundary contains $C(v) \cap C(vs)$.

In the remainder of this section, we consider a fully coloured graph with a realisation, and use the above notation.

The remainder of this section is similar to [B, section 5.4.4].

Theorem 24. *Let $v, w \in V$, $s \in S$ and write $v' = vs$. Suppose that (v, v', w) is a semi-geodesic. Then $C(w) \subset H(v', s)$.*

Proof. Induction on $n = d(v', w)$. For $n = 0$ it is trivial. If $n \geq 1$, let $v'' = v't$ ($t \in S$) be a neighbour of v' such that (v', v'', w) is a semi-geodesic. Note that $s \neq t$ and that $v'' \neq v$.

Let R be the $\{s, t\}$ -residue through v' . For $a, b \in R$, let $d_0(a, b)$ be the least $k \geq 0$ such that there exist $s_1, \dots, s_k \in \{s, t\}$ with $b = as_1 \cdots s_k$. So $d_0(a, b) \geq d(a, b)$.

Let A denote the set of those $a \in R$ for which $d(v', w) = d_0(v', a) + d(a, w)$. Let $x \in A$ be an element with $d(x, w)$ minimal.

We have $\#R \geq 2$ because $v', v'' \in R$. Let $y \in R$ be a neighbour of x , that is, $d_0(x, y) = 1$.

We claim that (y, x, w) is a semi-geodesic. If not, we would have $d(w, y) = d(w, x) - 1$ and hence

$$\begin{aligned} d(w, v') &\leq d(w, y) + d(y, v') \leq d(w, y) + d_0(y, v') \\ &= (d(w, x) - 1) + d_0(y, v') \\ &\leq d(w, x) - 1 + d_0(x, v') + 1 = d(w, v'). \end{aligned}$$

So equality holds throughout, forcing $d(w, v') = d(w, y) + d_0(y, v')$, and therefore $y \in A$, contrary to $d(w, y) < d(w, x)$.

Note that $v'' \in A$, whence $d(w, x) \leq d(w, v'') < d(w, v')$. Therefore we may apply the induction hypothesis to the triples (x, w, r) for $r \in \{s, t\}$. We find that

$$C(w) \subset H(x, s) \cap H(x, t). \quad (25)$$

It follows that $d_0(x, v) > d_0(x, v')$, since otherwise

$$\begin{aligned} d(w, v) &\leq d(w, x) + d(x, v) \leq d(w, x) + d_0(x, v) \\ &< d(w, x) + d_0(x, v') = d(w, v'), \end{aligned}$$

a contradiction. By (17), this shows that $H(x, s) \cap H(x, t) \subset H(v', s)$. By (25) we find $C(w) \subset H(v', s)$ as required. \square

Corollary 26. *If $v, w \in V$ are distinct then $C(v)^0 \cap C(w)^0 = \emptyset$.*

Proof. Let (v, v', w) be a semi-geodesic with $v' = vs$, $s \in S$. Now apply theorem 24. \square

A *cell* is a set of the form $\sum_{s \in I} \mathbb{R}_{\geq 0} q(v, s)$ (which is $\{0\}$ if $I = \emptyset$) for $v \in V$, $I \subset S$.

Corollary 27. *Let X, Y be distinct cells. Then $X^0 \cap Y^0 = \emptyset$.*

Proof. Let v, w be vertices such that $X \subset C(v)$, $Y \subset C(w)$ with $n = d(v, w)$ minimal. (We don't assume that X is a "face" of $C(v)$ or Y is of $C(w)$.) If

$n = 0$ it is trivial so suppose $n > 0$. Let $v' = vs$ be a neighbour of v such that (v, v', w) is a semi-geodesic. Then $X \not\subset C(v')$ by minimality of n . So $X^0 \cap H(v', s) = \emptyset$. We also have $Y \subset C(w) \subset H(v', s)$ so $X^0 \cap Y^0 = \emptyset$. \square

The union of all $C(v)$ is denoted U and generalises the well-known Tits cone for Coxeter groups.

Corollary 28. *The following hold.*

- (a) U is convex.
- (b) For all $x, y \in U$, the line segment $[x, y] := \{tx + (1 - t)y \mid 0 \leq t \leq 1\}$ meets finitely many cells of U .

Proof. By corollary 27 we can prove parts (a) and (b) at once by showing that for all $x, y \in U$, the line segment $[x, y]$ is contained in the union of finitely many cells. Let v, w be vertices with $x \in C(v), y \in C(w), n = d(v, w)$ minimal. Induction on n . If $n = 0$ it is trivial. If $n > 0$, write $[x, y] \cap C(v) = [x, z]$. Since $y \notin C(v)$, we have $y \notin H(v, s)$ for some $s \in S$ with $z \in \partial H(v, s)$. Since $y \in C(w) \setminus H(v, s)$, it follows from theorem 24 that $d(v', w) < d(v, w)$. Since $z \in C(v')$, the segment $[z, y]$ is contained in finitely many cells by induction. Moreover, $[x, z]$ is clearly contained in finitely many cells. This proves the induction step which finishes the proof. \square

Corollary 29. *Every residue of a realisable fully coloured graph is simply 2-connected (hence is itself a fully coloured graph).*

Proof. Use corollary 28(a). \square

3 $(2, 3, \infty)$ -Graphs

Definition 30. A $(2, 3, \infty)$ -graph is a fully coloured graph (V, S, m) which admits a (necessarily essentially unique) realisation (13)–(17) with the following properties.

- We have $m(v; s, t) \in \{2, 3, \infty\}$ for all v, s, t . (31)

- We define a bijection $N: \{2, 3, \infty\} \rightarrow \{0, 1, 2\}$ by $N(2) = 0$, (32)
 $N(3) = 1$, $N(\infty) = 2$. Equivalently, $N(k) = 2 \cos(\pi/k)$. We put
 $n(v; s, t) := N(m(v; s, t))$ and $n(R; s, t) = n(v; s, t)$ if R is the
 $\{s, t\}$ -residue through v .

Suppose $vs = w$ ($v \in V, s \in S$). Then

$$\begin{aligned} p(v, s) \phi_{v,s} &= -p(w, s) + \sum_{t \in S \setminus \{s\}} n(v; s, t) p(w, t) \\ &= -p(w, s) + \sum_{t \in S \setminus \{s\}} 2 \cos \frac{\pi}{m(v; s, t)} p(w, t) \end{aligned}$$

Compare with (19).

The realisation with these properties is called the *standard realisation* in order to distinguish it from other realisations, if any. Note that the uniqueness of the standard realisation follows immediately from (32). \square

Recall definition 9 of automorphisms of fully coloured graphs.

Lemma 33. *Let Γ be a $(2, 3, \infty)$ -graph.*

- (a) *Every automorphism of Γ preserves the standard realisation, that is, makes (20) commute.*
- (b) *We have a faithful representation $\text{Aut}(\Gamma) \rightarrow \text{GL}(Q)$, $g \mapsto L_g$.*

Proof. Part (a) is clear; (b) follows from (a), lemma 21 and corollary 26. \square

Our next aim is to provide an explicit local criterion for a fully coloured graph to be a $(2, 3, \infty)$ -graph. We need the notion of structure sequence, which we shall now define (see figure 1).

Figure 1. Structure sequences.

This picture shows part of a 3-residue T containing an $\{s, t\}$ -residue $R = \{v_i \mid i\}$ with $m(R; s, t) = 3$. In the middle of every 2-residue R_i in T meeting R in an edge $\{v_i, v_{i+1}\}$ of colour $u \in \{s, t\}$ the picture shows the value of $n(R_i; r, u)$. The structure sequence for R is $(0, 0, 1, 0, 0, 1)$.

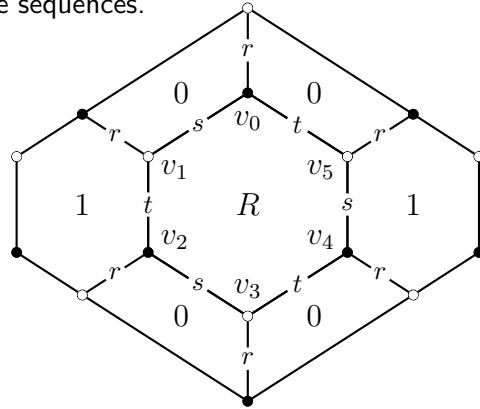

Definition 34. Let (V, S, m) be a fully coloured graph satisfying (31). Let $s, t \in S$ be distinct and let $R \subset V$ be an $\{s, t\}$ -residue. Write $k = m(R; s, t)$ and $R = \{v_i \mid i \in \mathbb{Z}/2k\}$, $v_{2i-1}t = v_{2i} = v_{2i+1}s$ for all i (see figure 1). Note that there is no guarantee yet that $\#R = 2k$. The map

$$\begin{aligned}
 f: \mathbb{Z}/2k &\longrightarrow \{0, 1, 2\} \\
 2i &\longmapsto n(v_{2i}; r, s) \\
 2i + 1 &\longmapsto n(v_{2i+1}; r, t)
 \end{aligned}$$

is called the *structure sequence* of the $\{s, t\}$ -residue R . We denote it by $(f(1), \dots, f(2k))$. We always consider two structure sequences to be equal if they differ only by a cyclic permutation or reversal. Therefore the structure sequence is determined by $(R; s, t)$. We don't associate structure sequences to infinite 2-residues. \square

Theorem 35.

- (a) *Let Γ be a fully coloured graph satisfying (31). Then Γ is a $(2, 3, \infty)$ -graph if and only if the following hold.*

$$\text{All structure sequences of length 4 are of the form } (n_1, n_2, n_1, n_2), \quad n_1, n_2 \in \{0, 1, 2\}. \tag{36}$$

All structure sequences of length 6 are of the form $(n_i)_{i \in \mathbb{Z}/6}$ where $n_i \in \{0, 1, 2\}$ are such that $(-1)^i(n_i - n_{i+3})$ is independent on i . (37)

- (b) In particular, Γ is a $(2, 3, \infty)$ -graph if and only if its k -residues are for all $k \leq 3$.
- (c) The length 6 structure sequences satisfying the condition of (37) are precisely

$$\begin{array}{lll}
 (0, 0, 0, 0, 0, 0) & (0, 0, 2, 0, 0, 2) & (1, 2, 2, 1, 2, 2) \\
 (0, 0, 1, 0, 0, 1) & (0, 2, 0, 2, 0, 2) & (2, 2, 2, 2, 2, 2) \\
 (0, 1, 0, 1, 0, 1) & (0, 2, 2, 0, 2, 2) & (1, 1, 1, 0, 2, 0) \\
 (0, 1, 1, 0, 1, 1) & (1, 1, 2, 1, 1, 2) & (1, 1, 1, 2, 0, 2) \\
 (1, 1, 1, 1, 1, 1) & (1, 2, 1, 2, 1, 2) & (0, 1, 2, 0, 1, 2)
 \end{array}$$

up to cyclic permutation and reversing.

Proof. Define $P(v)$ ($v \in V$) and $\phi_{v,s}: P(v) \rightarrow P(vs)$ uniquely by (13), (14), (32). By the definition of realisations of fully coloured graphs, Γ is a $(2, 3, \infty)$ -graph if and only if (15), (16) and (17) hold.

Let $P^*(v)$ be the dual to $P(v)$. Let $\langle \cdot, \cdot \rangle: P(v) \times P^*(v) \rightarrow \mathbb{R}$ be the natural pairing and let $\{p^*(v, s) \mid s \in S\}$ be the dual basis of $P^*(v)$ defined by

$$\langle p(v, s), p^*(v, t) \rangle = \begin{cases} 1 & \text{if } s = t, \\ 0 & \text{otherwise.} \end{cases}$$

Then $\phi_{v,s}^{-1}$ induces a map $\phi_{v,s}^*: P^*(v) \rightarrow P^*(w)$. For all $v \in V$ and all distinct $s, t \in S$ we have

$$\begin{aligned}
 p^*(v, s) \phi_{v,s} &= -p^*(vs, s), \\
 p^*(v, t) \phi_{v,s} &= p^*(vs, t) + n(v; s, t) p^*(vs, s).
 \end{aligned}
 \tag{38}$$

Let (39_{k=2}) and (39_{k=3}) denote the relevant special cases of the following statement.

- Let v_0, s, t be such that $m(v_0; s, t) = k$. Let $\{v_i \mid i \in \mathbb{Z}/2k\}$ be the $\{s, t\}$ -residue through v_0 , and $v_i s_i = v_{i+1}$ for all i , and $s_i = s$ for even i and $s_i = t$ for odd i . Then $\phi_{v_1, s_1} \cdots \phi_{v_n, s_n} = 1$. (39)

Then (15) is equivalent to (39_{k=2}) and (39_{k=3}). We begin by proving that (39_{k=3}) is equivalent to (37) if $\#S \geq 3$. Let s, t, v_i, s_i be as in (39_{k=3}) and let $r \in S \setminus \{s, t\}$. Define the rows of vectors

$$f_i := (p^*(v_i, s), p^*(v_i, t), p^*(v_i, r)) \quad \text{if } i \text{ is even,} \tag{40}$$

$$f_i := (p^*(v_i, t), p^*(v_i, s), p^*(v_i, r)) \quad \text{if } i \text{ is odd.} \tag{41}$$

After interchanging s, t if necessary, we have $f_i \phi_{v_i, s_i} = f_i M(n_i)$ for all i , where ϕ_{v_i, s_i} acts componentwise and

$$M(n) = \begin{pmatrix} 0 & -1 & 0 \\ 1 & 1 & 0 \\ 0 & n & 1 \end{pmatrix}.$$

We have

$$\begin{aligned} M(n_1)M(n_2)M(n_3) &= \begin{pmatrix} 0 & -1 & 0 \\ 1 & 1 & 0 \\ 0 & n_1 & 1 \end{pmatrix} \begin{pmatrix} 0 & -1 & 0 \\ 1 & 1 & 0 \\ 0 & n_2 & 1 \end{pmatrix} M(n_3) \\ &= \begin{pmatrix} -1 & -1 & 0 \\ 1 & 0 & 0 \\ n_1 & n_1 + n_2 & 1 \end{pmatrix} \begin{pmatrix} 0 & -1 & 0 \\ 1 & 1 & 0 \\ 0 & n_3 & 1 \end{pmatrix} = \begin{pmatrix} -1 & 0 & 0 \\ 0 & -1 & 0 \\ n_1 + n_2 & n_2 + n_3 & 1 \end{pmatrix} \end{aligned} \quad (42)$$

which is an involution. It follows that

$$\begin{aligned} \prod_{i=1}^6 M(n_i) = 1 &\iff M(n_1)M(n_2)M(n_3) = M(n_4)M(n_5)M(n_6) \\ &\iff (n_4, n_5, n_6) = (n_1, n_2, n_3) + (k, -k, k) \text{ for some } k \\ &\iff (-1)^i(n_i - n_{i+3}) \text{ is independent of } i. \end{aligned}$$

We have proved that $(39_{k=3})$ is equivalent to (37) if $\#S \geq 3$. In case $\#S < 3$ the proof is the same as above except that r is absent, that is, the last row and column of $M(n)$ are removed.

Next we prove that $(39_{k=2})$ is equivalent to (36). Let s, t, v_i, s_i be as in $(39_{k=2})$ and let $r \in S \setminus \{s, t\}$. As before, define f_i by (40), (41). After interchanging s, t if necessary, we have $f_i \phi_{v_i, s_i} = f_i L(n_i)$ for all i where

$$L(n) = \begin{pmatrix} 0 & -1 & 0 \\ 1 & 0 & 0 \\ 0 & n & 1 \end{pmatrix}.$$

Now

$$L(n_1)L(n_2) = \begin{pmatrix} 0 & -1 & 0 \\ 1 & 0 & 0 \\ 0 & n_1 & 1 \end{pmatrix} \begin{pmatrix} 0 & -1 & 0 \\ 1 & 0 & 0 \\ 0 & n_2 & 1 \end{pmatrix} = \begin{pmatrix} -1 & 0 & 0 \\ 0 & -1 & 0 \\ n_1 & n_2 & 1 \end{pmatrix}$$

from which it readily follows that

$$L(n_1) \cdots L(n_4) = 1 \iff (n_1, n_2, n_3, n_4) = (n_1, n_2, n_1, n_2).$$

This proves that $(39_{k=2})$ is equivalent to (36). (The case $\#S < 3$ is again a consequence of the same computation). Therefore, (15) is equivalent to (36) and (37). Assume now (15). It remains to prove (16) and (17).

Condition (16) states that neighbouring open chambers are disjoint; it holds because of the negative sign in (38).

The proof of (17) splits into three cases, according to whether $m(R; s, t)$ is 2, 3 or ∞ .

Suppose first that $m(R; s, t) = 3$. Let s, t, v_i, s_i be as in $(39_{k=3})$. Let W be the span of X , that is, $W = \sum_{u \in S \setminus \{s, t\}} \mathbb{R} q(v_1, u)$ and define

$$\begin{aligned} g_i &:= (q(v_i, s) + W, q(v_i, t) + W)^T && \text{if } i \text{ is even,} \\ g_i &:= (q(v_i, t) + W, q(v_i, s) + W)^T && \text{if } i \text{ is odd} \end{aligned}$$

Figure 2. $A(3, 7)$.

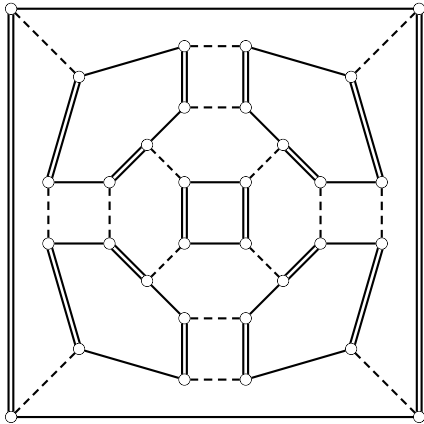

The $(2, 3)$ -graph $A(3, 7)$. The three edge colours are here indicated by different line types. The graph has 32 vertices and 48 edges and its automorphism group is isomorphic to $S_4 \times C_2$. Its colour preserving automorphism group is isomorphic to $(C_2)^3$ and is generated by the reflections in the edges of the gray region in the dual picture of figure 8(b). Its Poincaré polynomial is $[1][3]^2$ (see [OT, section 2.3] for the definition of the Poincaré polynomial; we use the notation $[n] = 1 + nt$). Being a $(2, 3)$ -graph, $A(3, 7)$ has a realisation by hyperplanes; it is given by $xyz(x + y)(y + z)(z + x)(x + y + z) = 0$.

where T denotes transpose. Taking transposes everywhere in our identity $f_i \phi_{v_i, s_i} = f_i M(n_i)$ and removing the third entries, we find $g_{i+1} = K(n_i) g_i$ for all i , where $K(n)$ is the transpose of $M(n)$ without the last row and columns, that is, $K(n) = \begin{pmatrix} 0 & 1 \\ -1 & 1 \end{pmatrix}$. By (42) or direct computation we find $K(n)^3 = -1$ and $g_{i+3} = -g_i$ as desired. This proves (17) if $m(R; s, t) = 3$. The case where $m(R; s, t) = 2$ is similar and left to the reader.

Finally, we prove (17) if $m(R; s, t) = \infty$. Define s, t, v_i, s_i, W, g_i as before. Now (32) yields that $g_i - 2g_{i-1} + g_{i-2} = 0$ for all i . Let $h: Q/W \rightarrow \mathbb{R}$ be the linear map defined by $h(g_0) = 1$ and $h(g_1) = 1$. Then $h(g_i) = 1$ for all i . It follows that $h(C(v) + W) \subset \mathbb{R}_{>0}$ for all $v \in R$, that is, the half-space

$$H := \{x \in Q \mid h(x + W) > 0\}$$

contains $\cup_{v \in R} C(v)$. Its boundary contains W and therefore X . This proves (17) if $m(R; s, t) = \infty$.

This finishes the proof of (a). Part (b) follows immediately from (a). Part (c) is straightforward. \square

With a little work, part (b) of the above theorem can be stated for all fully coloured graphs — it isn't confined to $(2, 3)$ -graphs. Moreover, the natural proof of it is almost a tautology. We won't need any of this.

The *rank* of a fully coloured graph (V, S, m) is defined to be $\#S$.

The *product* of two fully coloured graphs (V_i, S_i, m_i) ($i = 1, 2$) is defined to be $(V_1 \times V_2, S_1 \sqcup S_2, m)$ (\sqcup is disjoint union) where

$$\begin{aligned} (v_1, v_2) s_1 &= (v_1 s_1, v_2) && \text{if } v_i \in V_i \text{ for all } i \text{ and } s_1 \in S_1, \\ (v_1, v_2) s_2 &= (v_1, v_2 s_2) && \text{if } v_i \in V_i \text{ for all } i \text{ and } s_2 \in S_2, \\ m((v_1, v_2); s, t) &= m_i(v_i; s, t) && \text{if } s, t \in S_i, \\ m((v_1, v_2); s_1, s_2) &= 2 && \text{if } s_i \in S_i \text{ for all } i. \end{aligned}$$

It is clear that the product of two $(2, 3, \infty)$ -graphs is again a $(2, 3, \infty)$ -graph. A fully coloured graph is *irreducible* if it is not isomorphic to a product of two fully coloured graphs of positive rank.

By a $(2, 3)$ -graph we mean a $(2, 3, \infty)$ -graph (V, S, m) such that $m(v; s, t) \in \{2, 3\}$ for all v, s, t . We aim to classify the irreducible $(2, 3)$ -graphs of rank 3. Two of these are well-known: they are the Coxeter $(2, 3)$ -graphs A_3 and \tilde{A}_2 . For names of Coxeter groups, see [B, section 6.4.1], [H, 2.4].

We define a fully coloured graph $A(3, 7)$ of rank 3 by figure 2. Using theorem 35, it is easy to observe that it is a $(2, 3)$ -graph. In [G1] $A(3, 7)$ (or the arrangement dual to it) is called $A_1(7)$ and in [G2] it is $A(7, 1)$.

Proposition 43. *Up to isomorphism there are just three irreducible $(2, 3)$ -graphs of rank 3: A_3 , \tilde{A}_2 and $A(3, 7)$.*

Proof. Using theorem 35 this is an easy exercise involving drawings of graphs, and is left to the reader. \square

Note that \tilde{A}_2 is infinite while A_3 and $A(3, 7)$ are finite.

4 An example

4.1 An extension of the symmetric group

From now on we fix an integer $n \geq 0$. Let G_n be the free monoid on a set $T_n \subset G_n$ of $\binom{n+1}{2}$ elements written

$$T_n = \left\{ \binom{a}{b} \mid a, b \in \{0, 1, \dots, n\}, a < b \right\}.$$

A subset $R \subset G_n$ is *closed under cyclic permutations* if $ab \in R$ implies $ba \in R$, for all $a, b \in G_n$. We call ba a *cyclic permutation* of ab .

We define $Q_n \subset G_n$ to be the smallest subset, closed under cyclic permutations, containing

$$\binom{a}{b} \binom{c}{d} \binom{a}{b} \binom{c}{d}$$

whenever $0 \leq a < b \leq c < d \leq n$;

$$\binom{a}{b} \binom{a+x}{b-y} \binom{a}{b} \binom{a+y}{b-x}$$

whenever $x, y \geq 0$ and $0 \leq a < a+x+y < b \leq n$; and

$$\binom{a}{b-z} \binom{a+y}{b} \binom{a}{b-x} \binom{a+z}{b} \binom{a}{b-y} \binom{a+x}{b}$$

whenever $x, y, z > 0$ and $0 \leq a \leq a+x+y+z = b \leq n$.

In order to motivate the definition of Q_n , note that the action of G_n on $\{1, \dots, n\}$ defined by

$$\binom{a}{b}(x) = \begin{cases} a+b+1-x & \text{if } a+1 \leq x \leq b, \\ x & \text{otherwise} \end{cases} \quad (44)$$

has the property that the elements of Q_n act trivially.

Let K_n be the group presented by the generating set T_n and relations $s^2 = 1$ for all $s \in T_n$ and the relations in Q_n . One of our aims is to show that K_n is naturally the vertex set of a $(2, 3)$ -graph.

If one drops the relations of length 6 from the presentation of K_n one obtains a group similar to the *cactus group* defined on page 118 of [DJS].

4.2 Admissible graphs

We observe now:

◦ For all distinct $a, b \in T_n$, the set $abG_n \cap Q_n$ has precisely one element. Also, $a^2G_n \cap Q_n = \emptyset$ for all $a \in T_n$. (45)

◦ The set Q_n is invariant under reversal, that is, under the anti-automorphism of G_n which fixes every element of T_n . (46)

Definition 47. We define an action $T_n \times G_n \rightarrow T_n$ written $(a, b) \mapsto a * b$ as follows. Firstly, $a * a = a$ for all $a \in T_n$. Let $a, b, c \in T_n$ and assume that Q_n meets $abcG_n$. Then $a * b = c$.

Note that this is well-defined by (45). Also note that $(a * b) * b = a$ for all $a, b \in T_n$ by (46). Later on in proposition 68 we prove that it descends to an action $T_n \times K_n \rightarrow T_n$.

Definition 48. (a). For any set I , we define U_I to be the set of injective maps $I \rightarrow T_n$.

(b). Recall that F_I is the free monoid on I . We define an action $U_I \times F_I \rightarrow U_I$ written $(u, g) \mapsto u \nabla g$ by $[u \nabla s](t) = u(t) * u(s)$ for all $s, t \in I$. In particular, we have $[u \nabla s](s) = u(s)$ for all $s \in I$. Note also that $u \nabla ss = u$ for all $s \in I$.

Lemma 49. Let $h \in G_n$, $u_0 \in U_I$. Define $u_i \in U_I$ for $0 < i \leq k$ and $s_i \in I$ for $0 \leq i \leq k$ uniquely by

$$h = u_0(s_0) \cdots u_{k-1}(s_{k-1}),$$

$$u_i \nabla s_i = u_{i+1} \quad \text{for all } i.$$

- (a) If $h \in Q_n$ then $s_i = s_{i+2}$ for all i .
- (b) Conversely, if $s_i = s_{i+2}$ for all i then there exists $h' \in G_n$ such that hh' is a power of an element of Q_n .
- (c) We have $u_k(r) = u_0(r) * h$ for all $r \in I$.
- (d) We have $u_0 = u_k \Leftrightarrow a * h = a$ for all $a \in u_0(I)$.

Proof. Proof of (a). Write $h = a_0 \cdots a_{k-1}$, $a_i \in T_n$. For all i we have $u_{i+1}(s_i) = u_i(s_i)$ because $u_{i+1} = u_i \nabla s_i$. Therefore,

$$\begin{aligned} u_i(s_{i-1}) &= u_{i-1}(s_{i-1}) = a_{i-1} = a_{i+1} * a_i = u_{i+1}(s_{i+1}) * u_i(s_i) \\ &= u_{i+1}(s_{i+1}) * u_{i+1}(s_i) = (u_{i+1} \nabla s_i)(s_{i+1}) = u_i(s_{i+1}) \end{aligned}$$

thus proving (a).

Part (b) is similar to (a) and left to the reader.

Proof of (c). We have $u_i(r) * a_i = u_{i+1}(r)$ because $u_i(r) * a_i = u_i(r) * u_i(s_i) = (u_i \nabla s_i)(r) = u_{i+1}(r)$. It follows that $u_0(r) * h = u_0(r) * a_0 \cdots a_{k-1} = u_k(r)$.

Proof of (d). We have

$$\begin{aligned} u_0 = u_k &\iff u_0(r) = u_k(r) \text{ for all } r \in I \\ &\iff u_0(r) = u_0(r) * h \text{ for all } r \in I && \text{by (c)} \\ &\iff a = a * h \text{ for all } a \in u_0(I). && \square \end{aligned}$$

We shall prove that there exists a $(2, 3)$ -graph whose vertex set is K_n and whose edges are $\{x, xa\}$ whenever $x \in K_n$, $a \in T_n$. The colour of the edge $\{x, xa\}$ cannot depend only on a , because otherwise K_n would be a Coxeter group with T_n as the standard generating set (see lemma 10) which easily leads to a contradiction. Before giving the correct edge colouring, we define a closely related groupoid R_I .

Recall that a groupoid is a category all of whose morphisms are isomorphisms. If X, Y are objects of a category C we write $C(X, Y)$ for the set of morphisms of C from X to Y . All our categories are on the right, that is, the composition $C(X, Y) \times C(Y, Z) \rightarrow C(X, Z)$ is written $(f, g) \mapsto fg$ (rather than gf).

Definition 50. For any set I , we define a groupoid R_I with object set U_I by the presentation with generators

$$\begin{pmatrix} u \\ s \\ u \nabla s \end{pmatrix} \in R_I(u, u \nabla s)$$

whenever $u \in U_I$, $s \in I$, and relations

$$\begin{pmatrix} u_0 \\ s \\ u_1 \end{pmatrix} \begin{pmatrix} u_1 \\ t \\ u_2 \end{pmatrix} \begin{pmatrix} u_2 \\ s \\ u_3 \end{pmatrix} \begin{pmatrix} u_3 \\ t \\ u_4 \end{pmatrix} \cdots \begin{pmatrix} u_{2k-2} \\ s \\ u_{2k-1} \end{pmatrix} \begin{pmatrix} u_{2k-1} \\ t \\ u_{2k} \end{pmatrix} \quad (51)$$

whenever $u_0 = u_{2k}$ and either $s = t$ or the element

$$h := u_0(s) u_1(t) u_2(s) u_3(t) \cdots u_{2k-2}(s) u_{2k-1}(t) \quad (52)$$

is a power of an element of Q_n .

Lemma 53. *Let I be a set. There exists a unique functor $F: R_I \rightarrow K_n$ (where we consider K_n as a groupoid with just one object) such that*

$$F \begin{pmatrix} u \\ s \\ u \nabla s \end{pmatrix} = u(s) \quad (54)$$

for all $s \in I$, $u \in R_I$.

Proof. Recall that R_I is defined by a certain presentation. The F -values of the generators of R_I are prescribed by (54) and unicity of F follows.

In order to prove the existence of F , we need to prove that (54) takes relations for R_I to the identity morphism in K_n . For the relation (51) with $s = t$ this holds because $u(s)^2 = 1$ in K_n . Consider finally the relation (51) where $u_0 = u_{2k}$, and h defined by (52) is a power of an element of Q_n . Then h defines the identity element in K_n . Moreover, applying (54) to each of the $2k$ factors of the relation (51) yields precisely h , thus finishing the proof. \square

Remark 55. It is clear that the following assertions are equivalent:

- We have $a * g = a$ for all $a \in T_n, g \in Q_n$. (56)
- The condition that $u_0 = u_{2k}$ in definition 50 is a consequence of the other assumptions. (57)
- The restriction $R_I(u, -) \rightarrow K_n$ of the functor F of lemma 53 is injective. (58)

In proposition 68 we shall see that these are true. This could be proved here directly by a tedious calculation, but better is to give it as a byproduct of some more general calculations in example 62 that we need to do anyway.

Definition 59. Let $u \in U_I$. We define a fully coloured graph $\Gamma(u) = (V, I, m)$ called an *admissible graph* as follows. Firstly, $V := R_I(u, -)$, the set of morphisms in R_I from u to any object. The action $V \times I \rightarrow V$ is defined by

$$(v, s) \mapsto vs := v \cdot \begin{pmatrix} u_0 \\ s \\ u_0 \nabla s \end{pmatrix} \quad \text{whenever } v \in R_I(u, u_0)$$

where a dot denotes composition in R_I . We define m to be the minimal possible: for $v \in V$ and $s, t \in I$ distinct, we let $m(v; s, t)$ be the least $k > 0$ such that $v(st)^k = v$.

It is clear that $\Gamma(u)$ is a fully coloured graph. Notice that $\Gamma(u)$ has a natural base vertex $1_u \in R_I(u, u)$. Note that if u_1, u_2 are isomorphic objects of R_I then there is an isomorphism of fully coloured graphs $\Gamma(u_1) \rightarrow \Gamma(u_2)$ (preserving I pointwise) but it may not respect the base points. Therefore we may reasonably write Γ_n instead of $\Gamma(u)$ if $u: I \rightarrow T_n$ is bijective. Examples of admissible graphs can be found in figures 5, 7 and 8.

4.3 Equivalence relations

Recall that $T_n = \left\{ \binom{a}{b} \mid 0 \leq a < b \leq n \right\}$.

Definition 60. (a). For a subset $A \subset \{0, 1, \dots, n\}$ we define $T(A) := \left\{ \binom{a}{b} \mid a, b \in A, a < b \right\} \subset T_n$.

(b). Let $u \in U_I$. The *support* of u is defined to be $\text{supp}(u) := \{a, b \mid \binom{a}{b} \in u(I)\}$, that is, the smallest A such that $u(I) \subset T(A)$.

(c). Let $u_1, u_2 \in U_I$ and write $A_i = \text{supp}(u_i)$ ($i \in \{1, 2\}$). We write $u_1 \sim u_2$ if there exists a map $f: A_1 \rightarrow A_2$ which is either an increasing bijection or a decreasing one, and $u_2 = g \circ u_1$ where $g: T(A_1) \rightarrow T(A_2)$ is defined by $g\left(\binom{a}{b}\right) = \binom{f a}{f b}$.

(d). For the sake of question 78, we include the following definition. Let $u_1, u_2 \in U_I$ and suppose $A = \text{supp}(u_1) = \text{supp}(u_2)$. By a cyclic permutation of A we mean a power of the permutation of A which takes every non-maximal element of A to the next bigger element of A . We say that u_1 is a *cyclic permutation* of u_2 if there exists a cyclic permutation f of A such that $u_2 = g \circ u_1$ where $g: T(A) \rightarrow T(A)$ is defined by $g \begin{pmatrix} a \\ b \end{pmatrix} = \begin{pmatrix} fa \\ fb \end{pmatrix}$.

Clearly, \sim is an equivalence relation on U_I .

Lemma 61. *Let $u_1, u_2 \in U_I$ be such that $u_1 \sim u_2$.*

(a). *Then $u_1 \nabla g \sim u_2 \nabla g$ for all $g \in F_I$.*

(b). *Write $E_j := u_j \nabla F_I$. Then there is a unique isomorphism of F_I -sets $f: E_1 \rightarrow E_2$ (that is, a bijection such that $f(u \nabla g) = (fu) \nabla g$ for all $u \in E_1, g \in F_I$) such that $f(u_1) = f(u_2)$.*

(c). *For $j \in \{1, 2\}$, let $R_j \subset R_I$ be the component of u_j , that is, the biggest subcategory of R_I whose object set is E_j . Then there is a unique isomorphism of categories $h: R_1 \rightarrow R_2$ such that $h(u) = f(u)$ for all objects u (f as in (b)) and*

$$h \begin{pmatrix} u_3 \\ s \\ u_4 \end{pmatrix} = \begin{pmatrix} f(u_3) \\ s \\ f(u_4) \end{pmatrix}$$

whenever the left hand side is defined.

(d). *There is a unique isomorphism $\Gamma(u_1) \rightarrow \Gamma(u_2)$ of pointed fully coloured graphs which preserves I pointwise.*

Proof. Easy and left to the reader. □

Let \approx be the equivalence relation on U_I generated by \sim defined in definition 60 and \cong (isomorphism in the groupoid R_I).

Let \approx_s be the equivalence relation on U_I generated by \approx and the graph of the symmetric group on I . In other words, $u_1 \approx_s u_2$ if and only if $u_1 \approx u_2 \circ \pi$ for some permutation π of I . Define \sim_s and \cong_s likewise.

It is natural to draw pictures of objects of R_I . The convention is easily understood from figure 3 which shows an element of U_I and some of its equivalence classes, and figure 4 which shows pictures for edges in admissible graphs. Figure 5 shows an admissible graph.

4.4 Main result

Example 62. We now have a detailed look at three rank 3 admissible graphs. Our understanding of them will be crucial in the case-by-case proof of theorem 67.

(a). One rank 3 admissible graph Γ is given in figure 7. You should verify it. The verification is helped by the schematic version of the graph in figure 6 and the order 6 colour preserving automorphism group (which fixes the 2-residue numbered 1). Note that the vertices can be taken to be \sim -classes by lemma 61.

An observation which will be important in the proof of theorem 67 is that Γ is a (2, 3)-graph. Indeed, it is isomorphic to the Coxeter graph of type A_3 .

Figure 3. Vertices of admissible graphs. Let $I = \{r, s, t\}$ have 3 elements. Part (a) shows a picture of the object $u \in U_I$ defined by $u(r) = \binom{0}{3}$, $u(s) = \binom{1}{6}$, $u(t) = \binom{1}{7}$. The picture in (a) is flat but we usually prefer the (equivalent) curled up version of (b)–(d). In (b) we see the \sim -class of u . The precise values 0, 1, 3, 6, 7 are forgotten but their ordering is not as it is still shown in the picture. In (c) we divide out the symmetric group on I and in (d) we divide out \sim_s .

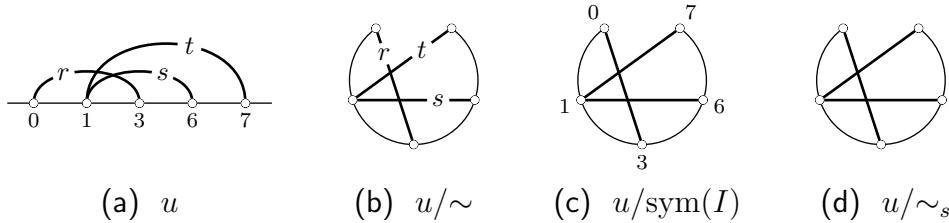
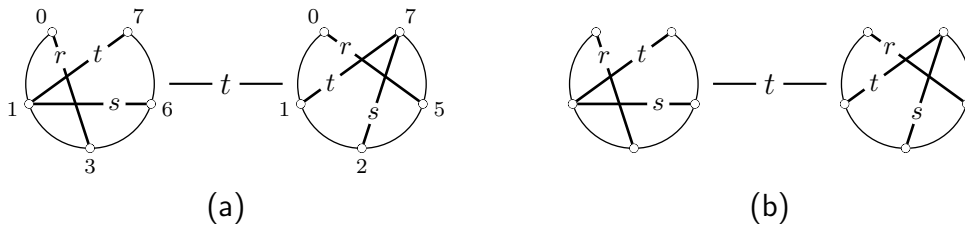

Figure 4. Edges of admissible graphs. Suppose that the left hand side in (a) depicts some $u \in U_I$ with $I = \{r, s, t\}$. Then the right hand side is $u \nabla t$. Part (b) is obtained from (a) by taking \sim -classes — we know by lemma 61 that admissible graphs survive division by \sim .



(b). Figure 8(a) shows part of another rank 3 admissible graph Γ . Convince yourself that it is correct. The dashed triangle is precisely $1/8$ of the whole graph. The colour preserving automorphism group of Γ is of order 8 and generated by the reflections in the edges of the dashed triangle.

Again, we observe that $\Gamma(u)$ is a $(2, 3)$ -graph (use theorem 35 or proposition 43). In the classification of rank 3 $(2, 3)$ -graphs (proposition 43) we said that it is of type $A(3, 7)$. See figure 2 for another picture of it. As every $(2, 3)$ -graph, it has a realisation as a hyperplane arrangement. This arrangement is shown in figure 8(b), which also serves to give a full picture rather than $1/8$ of it.

(c). Let I and $u \in U_I$ be such that $u(I) = \{\binom{0}{2}, \binom{1}{3}, \binom{2}{4}\}$. Then u is a single isomorphism class in R_I and one easily deduces that $\Gamma(u)$ must be a Coxeter fully coloured graph. Indeed it is of type A_3 and again it is a $(2, 3)$ -graph.

Definition 63. Let $u \in U_I$. We call u *reducible* if I can be written as the union of two non-empty disjoint sets A, B such that for all $(a, b) \in A \times B$ there exist $x, y \in T_n$ such that $u(a)u(b)xy \in Q_n$. Otherwise it is called *irreducible*.

For example, if the image of u is $\{\binom{1}{7}, \binom{2}{5}, \binom{3}{6}\}$ then u is reducible because of the partition $\{\binom{1}{7}\}, \{\binom{2}{5}, \binom{3}{6}\}$. See figure 5 for the associated reducible admissible graph.

Figure 5. An example of an admissible graph (on the left) together with the corresponding part of the Cayley graph of (K_n, T_n) (on the right). This graph is reducible, but the relation $\begin{pmatrix} 1 \\ 7 \end{pmatrix} \begin{pmatrix} 2 \\ 5 \end{pmatrix} \begin{pmatrix} 1 \\ 7 \end{pmatrix} \begin{pmatrix} 3 \\ 6 \end{pmatrix}$ is not of the form $abab$.

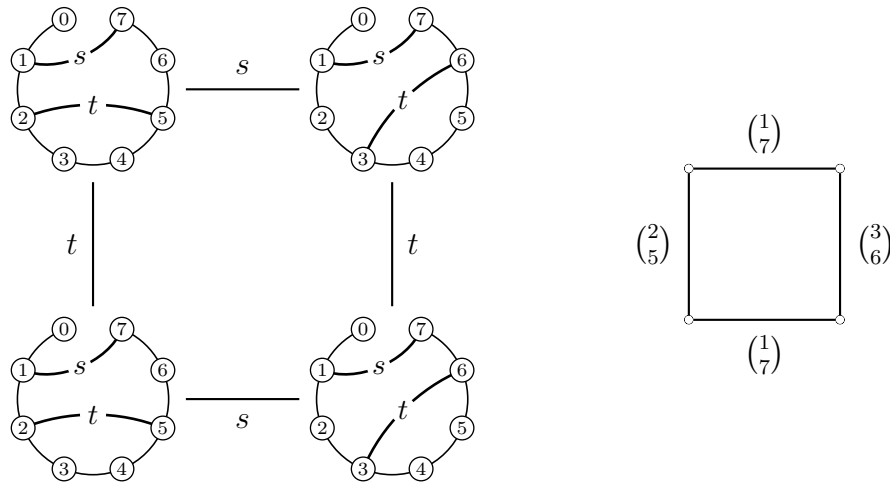

Figure 6. Schematic version of $\Gamma(u)$ for $u \in L_2 \cup L_3$. See figure 7 for a full picture. The colour preserving automorphism group of this graph has order 6 and preserves the 2-residue labelled 1.

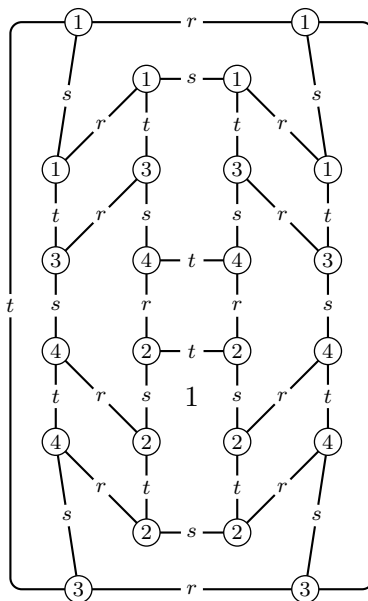

Figure 7. The admissible graph $\Gamma(u)$ for $u \in L_2 \cup L_3$. A schematic version of it is shown in figure 6.

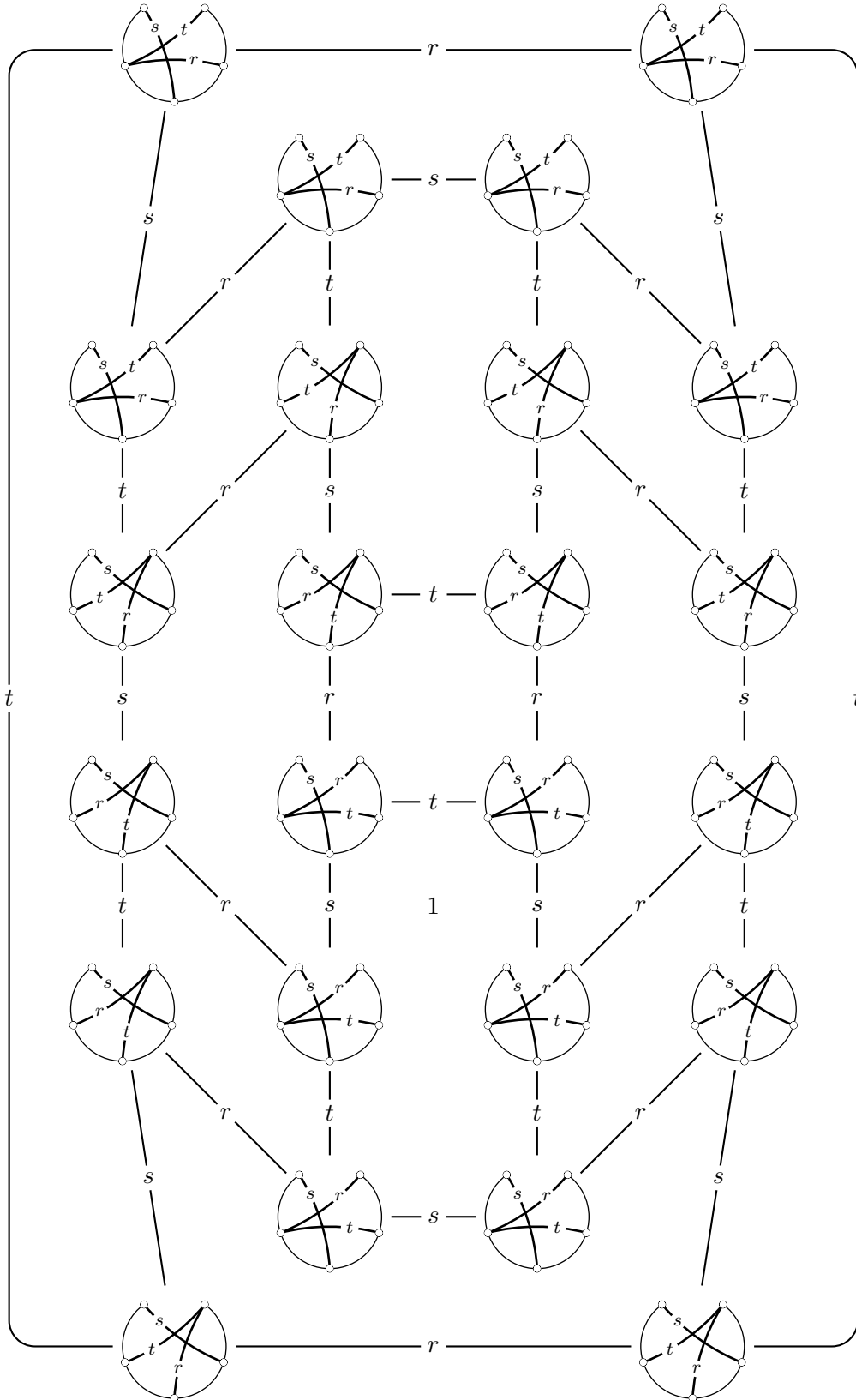
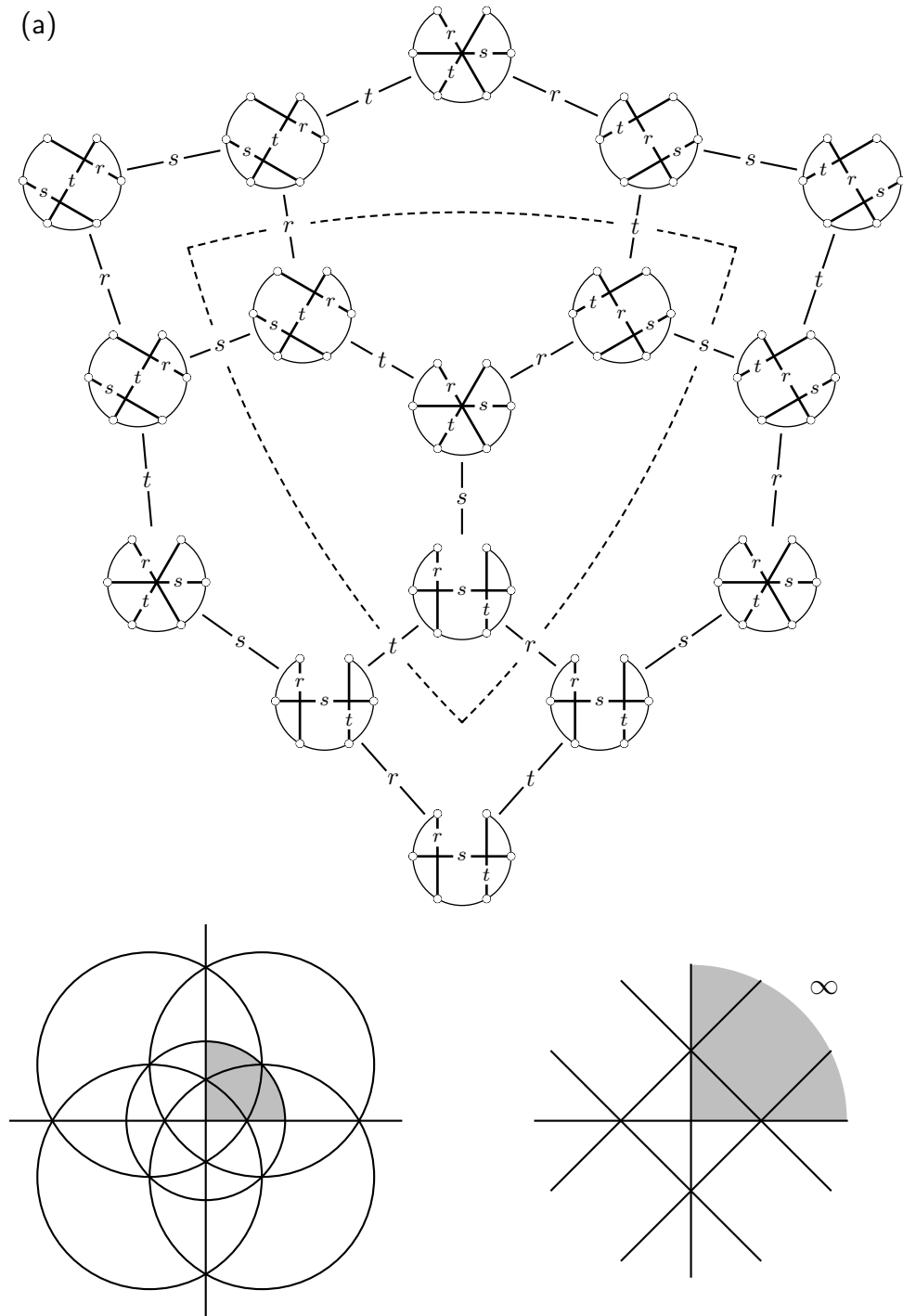

Figure 8. Picture (a). Part of the admissible graph $\Gamma(u)$ for $u \in L_4 \cup L_5 \cup L_6$. The dashed triangle is exactly one eighth of it and corresponds to the gray region of (b) and (c). **Pictures (b) and (c).** The line arrangement defined by $xyz(x+y)(y+z)(z+x)(x+y+z) = 0$. It is dual to the $(2, 3)$ -graph $A(3, 7)$. The gray region is the dashed triangle of (a). See figure 2 for $A(3, 7)$.



(b) Spherical picture of $A(3, 7)$.

(c) Projective picture of $A(3, 7)$.
The line at infinity is included.

Lemma 64.

(a) Let $a, b, c \in T_n$ be distinct. Define f, g, h uniquely by

$$f \in caG_n \cap Q_n, \quad g \in abG_n \cap Q_n, \quad h \in bcG_n \cap Q_n.$$

Suppose that f and g have length 4. Then $a * h = a$.

(b) Let $u \in U_I$. If u is reducible then $\Gamma(u)$ is reducible as a fully coloured graph.

Proof. Part (a) is a straightforward and not-so-tedious calculation, and rather similar to the existence of the homomorphism $K_n \rightarrow S_n$ given in (44). Part (b) follows immediately from (a). □

Lemma 65. Suppose that $n \geq 5$ and I is a set of 3 elements.

(a) There are precisely six \sim_s -classes L_1, \dots, L_6 of irreducible elements in U_I . They are given by the following representatives.

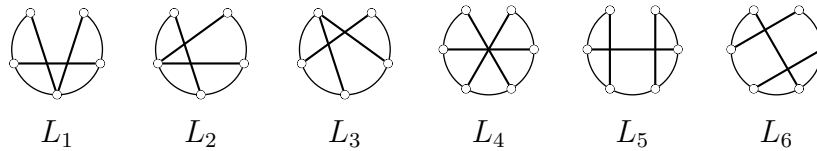

(b) The \approx_s -classes of irreducible elements in U_I are $L_1, L_2 \cup L_3$ and $L_4 \cup L_5 \cup L_6$.

(c) Every rank 3 admissible graph is a (2, 3)-graph.

Remark 66. The classes L_1, L_2, L_3 exist only if $n \geq 4$ and L_4, L_5, L_6 only if $n \geq 5$. In particular, irreducible rank 3 admissible graphs don't exist if $n < 4$. For simplicity, we put $n \geq 5$ in lemma 65.

Proof. It is easy and left to the reader to prove (a).

Proof of (b). The (connected) graph of example 62(a) and figure 7 involves L_2 and L_3 but no others (recall that reflection through a vertical line fixes every \sim -class by definition). Therefore $L_2 \cup L_3$ is a single \approx_s -class. Likewise, the graph of example 62(b) and figure 8(a) involves L_4, L_5 and L_6 but no others so $L_4 \cup L_5 \cup L_6$ is a \approx_s -class. Only one \sim_s -class L_1 remains which must therefore be a \approx_s -class as well; we looked at the related admissible graph in example 62(c).

Proof of (c). By (b) and lemma 64(b) we know all irreducible rank 3 admissible graphs. As we already observed in example 62, all of them are (2, 3)-graphs. It is easy and left to the reader to handle the reducible ones. □

Theorem 67. Every admissible graph is a (2, 3)-graph.

Proof. Consider an admissible graph $\Gamma(u) = (V, I, m)$, $u \in U_I$. In order to prove that $\Gamma(u)$ is connected, let f be any vertex of $\Gamma(u)$, that is, $f \in R_I(u, -)$. Recall also the vertex $1_u \in R_I(u, u)$ of $\Gamma(u)$. By definition of R_I , we can write

$$f = \begin{pmatrix} u_0 \\ s_0 \\ u_1 \end{pmatrix} \cdots \begin{pmatrix} u_{k-1} \\ s_{k-1} \\ u_k \end{pmatrix}$$

with $u_0 = u$. Therefore, $f = 1_u s_0 \cdots s_{k-1}$, which is in the same connected component as 1_u . This proves that $\Gamma(u)$ is connected. It is simply 2-connected by definition. Therefore, $\Gamma(u)$ is a fully coloured graph.

Next we prove that $m(v; s, t) \in \{2, 3\}$ for all v, s, t . In lemma 65(c) we observed this to be true in the rank 3 case. By lemma 49(d), this implies that $a * g = a$ for all $(a, g) \in T_n \times Q_n$. Using lemma 49(d) backwards we find that $m(v; s, t) \in \{2, 3\}$ for all v, s, t .

Recall that a $(2, 3)$ -graph is just a $(2, 3, \infty)$ -graph for which $m(v; s, t)$ is never infinite. By theorem 35 it remains to prove that all structure sequences of $\Gamma(u)$ satisfy (36) and (37). But all structure sequences of all admissible graphs occur in rank 3 admissible graphs. In lemma 65 we already observed the latter to be $(2, 3)$ -graphs, hence in particular to satisfy the required conditions (36) and (37). \square

Proposition 68. *We have $a * g = a$ for all $a \in T_n, g \in Q_n$.*

Proof. Let $b, c \in T_n$ be such that $g \in bcG_n$. Let I and $u \in U_I$ be such that $u(I) = \{a, b, c\}$.

If $\#I = 2$ then the result is immediate using the fact that $(d * e) * e = d$ for all $d, e \in T_n$, and that g has even length.

Suppose now that $\#I = 3$. If $\Gamma(u)$ is reducible, the result is precisely lemma 64(a), so suppose that $\Gamma(u)$ is irreducible.

By lemma 64(b) and lemma 64(b) we know all irreducible rank 3 admissible graphs. We drew these graphs in full detail in example 62. Inspection of the graphs immediately shows the promised result. \square

It follows from proposition 68 that there exists an action $T_n \times K_n \rightarrow T_n$ (descending from the star $*$ action by G_n) which by a slight abuse of notation we denote by a star again.

Corollary 69. *There exists a faithful linear representation of K_n of dimension $\#T_n$.*

Proof. Let $u \in U_I$ be such that $u: I \rightarrow T_n$ is bijective. By theorem 67, $\Gamma_n := \Gamma(u)$ is a $(2, 3)$ -graph. Consider its standard realisation with its usual notation as given by definition 30. Let $\text{Aut } \Gamma(u)$ be the automorphism group (see definition 9). By lemma 33, there exists a faithful representation $\text{Aut } \Gamma(u) \rightarrow \text{GL}(Q)$ of dimension $\#T_n$. It remains to embed K_n into $\text{Aut } \Gamma(u)$.

Consider the functor $F: R_I \rightarrow K_n$ from lemma 53. Restricting it gives a map $F_0: R_I(u, -) \rightarrow K_n$ which is bijective by proposition 68 and the equivalence (56) \Leftrightarrow (58). Moreover, the restriction $F_1: R_I(u, u) \rightarrow K_n$ is an injective group homomorphism whose image has finite index in K_n .

Let us first construct a faithful colour preserving left action of $R_I(u, u)$ on $\Gamma(u)$. We define the $R_I(u, u)$ -action on the vertex set $R_I(u, -)$ to be left multiplication

$$R_I(u, u) \times R_I(u, -) \longrightarrow R_I(u, -).$$

This extends to a unique $R_I(u, u)$ -action on $\Gamma(u)$ preserving the colours.

Thus, $R_I(u, u)$ has a faithful linear representation of dimension $\#T_n$. Inducing it up to K_n yields a faithful linear representation of K_n of dimension $\#T_n \#(K_n/F_1 R_I(u, u))$. To get the dimension as promised in the corollary, we need to work a bit harder.

Provided that $\#I = \#T_n$ (as it is) let F_I be the category with the same object set U_I as R_I and defined by the same presentation as R_I , except that there are no relations. Thus, F_I is a free category of which R_I is a natural quotient. Recall that K_n is a quotient of the free monoid G_n on T_n .

For every $v \in U_I$, we have a bijection $\Theta_v: G_n \rightarrow F_I(v, -)$ defined by

$$\Theta_v(a_0 \cdots a_{k-1}) = \begin{pmatrix} u_0 \\ s_0 \\ u_1 \end{pmatrix} \cdots \begin{pmatrix} u_{k-1} \\ s_{k-1} \\ u_k \end{pmatrix}$$

whenever $a_i \in T_n$, $u_0 = v$, $a_i = u_i(s_i)$ for all i . We write $v \otimes a_0 \cdots a_{k-1} := u_k$, thus obtaining a right G_n -action on U_I . We have

$$\Theta_v(fg) = \Theta_v(f) \Theta_{v \otimes f}(g) \quad \text{for all } v \in U_I, f, g \in G_n. \quad (70)$$

Next we prove:

- The map $\Theta_v: G_n \rightarrow F_I(v, -)$ descends to a map $\theta_v: K_n \rightarrow R_I(v, -)$. (71)

$$\begin{array}{ccc} G_n & \xrightarrow{\quad} & F_I(v, -) \\ \downarrow & \Theta_v & \downarrow \\ K_n & \xrightarrow{\quad} & R_I(v, -) \end{array}$$

In order to prove this, we must show that if $f, g, h \in G_n$ and $h \in Q_n$ or $h = a^2$ for some $a \in T_n$, then

$$\Theta_v(fhg) =_{R_I} \Theta_v(fg), \quad (72)$$

where $=_{R_I}$ means *having the same image in R_I* .

First we prove (72) if $f = g = 1$ and $h \in Q_n$. Then $a * h = a$ for all $a \in T_n$ by proposition 68. By lemma 49(d) we find $v \otimes h = v$. By lemma 49(a) $\Theta_v(h)$ is precisely a relation (51) in the presentation of R_I as required.

If $f = g = 1$ and $h = a^2$, $a \in T_n$ then

$$\Theta_v(h) = \Theta_v(a^2) = \begin{pmatrix} v \\ s \\ v \nabla s \end{pmatrix} \begin{pmatrix} v \nabla s \\ s \\ v \end{pmatrix} = 1_v$$

where $s = v^{-1}(a)$. This proves (72) if $f = g = 1$.

The general case follows by using (70):

$$\begin{aligned} \Theta_v(fhg) &= \Theta_v(f) \Theta_{v \otimes f}(h) \Theta_{v \otimes fh}(g) =_{R_I} \Theta_v(f) \Theta_{v \otimes fh}(g) \\ &= \Theta_v(f) \Theta_{v \otimes f}(g) = \Theta_v(fg), \end{aligned}$$

which finishes our proof of (72) and thereby (71). Of course, θ_u is the inverse of the restriction $F_0: R_I(u, -) \rightarrow K_n$ of the functor F .

We define a left K_n -action on $R_I(u, -)$, the vertex set of $\Gamma(u)$, by

$$\begin{aligned} K_n \times R_I(u, -) &\longrightarrow R_I(u, -) \\ (a, f) &\longmapsto a \wedge f := \theta_u[a \theta_u^{-1}(f)]. \end{aligned} \quad (73)$$

By proposition 68, there exists a right K_n -action on I , the colour set of $\Gamma(u)$,

$$\begin{aligned} I \times K_n &\longrightarrow I \\ (s, a) &\longmapsto s \sqcap a := u^{-1}[u(s) * a]. \end{aligned} \quad (74)$$

It remains to prove that (73) defines a K_n -action on the fully coloured graph $\Gamma(u)$, taking into account that the colours get permuted by (74). In formula,

$$(a \wedge f)s = a \wedge [f(s \sqcap a)] \quad \text{for all } a \in K_n, f \in R_I(u, -), s \in I. \quad (75)$$

By (71), \otimes descends to an action $U_I \times K_n \rightarrow U_I$ which by a slight abuse of notation we shall also denote $(v, a) \mapsto v \otimes a$.

Let us now prove that

$$(v \otimes a)s = v(s) * a \quad \text{for all } v \in U_I, a \in K_n, s \in I. \quad (76)$$

It suffices to prove this for $a \in T_n$. Then

$$\theta_v(a) = \begin{pmatrix} v \\ v^{-1}(a) \\ v \nabla v^{-1}(a) \end{pmatrix}$$

whence $(v \otimes a)(s) = [v \nabla v^{-1}(a)](s) = v(s) * a$, thus proving (76).

Next we prove

$$(u \otimes b)(s \sqcap a) = (u \otimes ab)(s) \quad \text{for all } a, b \in K_n, s \in I. \quad (77)$$

Indeed,

$$\begin{aligned} (u \otimes b)(s \sqcap a) &= [u(s \sqcap a)] * b && \text{by (76)} \\ &= [u(s) * a] * b && \text{by definition of } \sqcap \\ &= u(s) * ab \\ &= (u \otimes ab)(s) && \text{by (76)} \end{aligned}$$

thus proving (77).

Finally we are in a position to prove (75). Writing $b = \theta_u^{-1}(f) \in K_n$ we find

$$\begin{aligned} a \wedge [f(s \sqcap a)] &= a \wedge [\theta_u(b)(s \sqcap a)] \\ &= a \wedge \left[\theta_u(b) \cdot \begin{pmatrix} u \otimes b \\ s \sqcap a \\ (u \otimes b) \nabla (s \sqcap a) \end{pmatrix} \right] = a \wedge \left[\theta_u(b \cdot (u \otimes b)(s \sqcap a)) \right] \\ &= \theta_u(ab \cdot (u \otimes b)(s \sqcap a)) \stackrel{(77)}{=} \theta_u(ab \cdot (u \otimes ab)(s)) \\ &= \theta_u(ab) \cdot \begin{pmatrix} u \otimes ab \\ s \\ (u \otimes ab) \nabla s \end{pmatrix} = \theta_u(ab)s = (a \wedge \theta_u(b))s = (a \wedge f)s. \end{aligned}$$

This proves (75) and thereby the corollary. \square

Question 78. Recall that in definition 60(d) we defined cyclic permutations of elements of U_I . Observe now that every $u_1 \in L_1$ is a cyclic permutation of some $u_2 \in L_2$ (see lemma 65(a) for the classification of rank 3 admissible graphs). Also, $\Gamma(u_1)$ and $\Gamma(u_2)$ are isomorphic as fully coloured graphs because both are of Coxeter type A_3 as we saw in example 62(a) and (c). I don't know if this is a coincidence. Is it true in general that $\Gamma(u_3)$ and $\Gamma(u_4)$ are isomorphic whenever u_3 is a cyclic permutation of u_4 ?

We finish with a result without proof.

Proposition 79. *There are precisely four isomorphism classes of rank 4 irreducible finite (2, 3)-graphs. They are the Coxeter ones A_4 , D_4 and two more named $A(4, 13)$, $A(4, 15)$. Among them, D_4 is the only non-admissible one. Possible choices of $u_{13}, u_{15} \in U_I$ such that $A(4, 13) = \Gamma(u_{13})$, $A(4, 15) = \Gamma(u_{15})$ are as follows.*

$$u_{13}(I) = \left\{ \binom{0}{2}, \binom{0}{3}, \binom{0}{4}, \binom{1}{5} \right\}, \quad u_{15}(I) = \left\{ \binom{0}{2}, \binom{0}{4}, \binom{1}{5}, \binom{3}{6} \right\}.$$

Here are possible equations for $A(4, 13)$, $A(4, 15)$.

$$\begin{aligned} A(4,13) \quad &xyzw(x+y)(y+z)(z+w)(w+y)(y+z+w) \\ &(x+y+z)(x+y+w)(x+y+z+w)(x+2y+z+w) \end{aligned}$$

$$\begin{aligned} A(4,15) \quad &xyzw(x+y)(y+z)(z+w)(w+y) \\ &(x+y+z)(x+y+w)(y+z+w)(x+2y+z) \\ &(x+y+z+w)(x+2y+z+w)(x+2y+2z+w) \end{aligned}$$

The Poincaré polynomials of $A(3, 7)$, $A(4, 13)$, $A(4, 15)$ are, respectively, $[1][3]^2$, $[1][3][4][5]$, $[1][4][5]^2$. □

References

- [B] N. Bourbaki, *Groupes et algèbres de Lie*, Ch. 4-6, Hermann, Paris, 1968; Masson, Paris, 1981. English translation: Springer, Berlin, 2002.
- [DJS] M. Davis, T. Januszkiewicz, R. Scott, Fundamental groups of blow-ups. *Adv. Math.* **177** (2003), no. 1, 115–179.
- [G1] B. Grünbaum, *Arrangements and spreads*, AMS, Providence, 1972.
- [G2] B. Grünbaum, A catalogue of simplicial arrangements in the real projective plane, <http://hdl.handle.net/1773/2269>.
- [H] J.E. Humphreys, *Reflection groups and Coxeter groups*, Cambridge University Press, Cambridge, 1990.
- [OT] P. Orlik, H. Terao, *Arrangements of hyperplanes*. Springer, Berlin, 1992.
- [R] M. Ronan, *Lectures on buildings*. Academic Press, Boston, 1989.

- [T] J. Tits, A local approach to buildings, in *The geometric vein*, 519–547, Springer, New York-Berlin, 1981.
- [V] E.B. Vinberg, Discrete linear groups generated by reflections, *Math. USSR-Izv.* **5**, 1971, 1083-1119.